

U S A E H A

Environmental Health Aspects of Food Service Facilities Design Review



*U.S. Army Environmental Hygiene Agency
Aberdeen Proving Ground, Maryland 2101 0-5422*

Approved for public release; distribution unlimited.

TABLE OF CONTENTS

	Paragraph	Page
PURPOSE.....**.....*	1	1
SCOPE	2	1
REFERENCES	3	2
ABBREVIATIONS AND TERMS	4	2
USE OF CHECKLISTS	5	2

CHECKLISTS

1. FLOORS.....	1-1
2. WALLS.....	2-1
3. CEILING.....	3-1
4. SERVICE CONNECTIONS/UTILITIES	4-1
5. SANITARY WASTE DISPOSAL.....	5-1
6. BACK SIPHONAGE/BACKFLOW PREVENTION.....	6-1
7. BAR TYPE SINKS AND SODA FOUNTAINS	7-1
8. FOOD-WASTE GRINDERS.....	8-1
9. LIGHTING AND ELECTRICAL CONNECTIONS	9-1
10. VENTILATION SYSTEMS	10-1
11. GREASE REMOVAL SYSTEMS	11-1
12. GENERAL VENTILATION.....	12-1
13. BATHROOMS AND HAND WASHING FACILITIES	13-1
14. BATHROOM AND TOILET FACILITY VENTILATION.....	14-1
15. EMPLOYEE FACILITIES	15-1
16. BAND WASHING FACILITIES	16-1
17. GARBAGE AND REFUSE STORAGE.....	17-1
18. WATER SUPPLY.....	18-1
19. FOOD SERVICE EQUIPMENT (General Requirements)	19-1
20. MACHINE WAREWASHING.....	20-1
21. CHEMICAL SANITIZING - WAREWASHING MACHINES	21-1
22. MANUAL WAREWASHING.....	22-1
23. WAREWASHING FACILITIES (General).....	23-1
24. HOT WATER GENERATING EQUIPMENT.....	24-1
25. WALK-IN REFRIGERATORS AND STORAGE FREEZERS	25-1
26. RECEIVING AREAS.....	26-1
27. STORAGE (General).....	27-1
28. ADMINISTRATIVE AREAS.....	28-1

APPENDICES

A. REFERENCES.....	A-1
B. SERVICE CONNECTIONS.....	B-1
C. POTENTIAL CROSS-CONNECTION LOCATIONS	C-1

	Page
D. BACKFLOW PREVENTION DEVICES	D-1
E. HOT WATER GENERATING EQUIPMENT	E-1
F. EQUIPMENT INSTALLATION	F-1
G. WALK-IN REFRIGERATORS AND FREEZERS	G-1
GLOSSARY.....	Glossary-1



REPLY TO
ATTENTION OF

DEPARTMENT OF THE ARMY
U. S. ARMY ENVIRONMENTAL HYGIENE AGENCY
ABERDEEN PROVING GROUND, MARYLAND 21010-6422



HSHB-MI-S

May 1994

USAEHA TECHNICAL GUIDE NO. 194

ENVIRONMENTAL HEALTH ASPECTS OF
FOOD SERVICE FACILITIES
DESIGN REVIEW

1. PURPOSE

This technical guide (TG) --

a. Provides installation health authorities, particularly Environmental Science Officers, Sanitarians, and enlisted Preventive Medicine personnel, with the basic regulatory and design criteria necessary for reviewing planned renovation, remodeling, and new construction of food service facilities.

b. Is also suitable for--

(1) Conducting preoccupancy, acceptance, and pre-construction surveys.

(2) Reviewing work requests.

2. SCOPE

This TG--

a. IS limited to the physical plant and the equipment in a food service facility that relate to the facility's ability to handle, receive, store, process, and serve food in a sanitary manner. Safety issues such as selection of floor coverings, which impact sanitary conditions are included.

b. Contains criteria applicable to food service facilities on U.S. Army, U.S. Army Reserve, and National Guard installations (hereafter called "Army installation; These facilities include contractor owned, leased, or furnished food service facilities operated on Army installations as part of an overall contract food service operation.

c. Contains both regulatory requirements and recommendations.

(1) If a change or waiver to a requirement is requested, the reader should consult the reference(s) cited to determine if a specific item can be waived or if a substitute method or design that provides equal protection is allowed.

(2) The regulatory requirements for medical design review of food service facilities are contained in AR 40-5, AR 420-10, and TB MED 530.

3. REFERENCES

Appendix A provides a list of references.

4. ABBREVIATIONS AND TERMS

The glossary lists the abbreviations and defines the terms used throughout this document.

5. USE OF CHECKLISTS

a. The following checklists are designed--

(1) For use during comprehensive food service inspections or during pre-renovation or remodeling evaluations of a facility. Checklist items for inspections only are identified by an asterisk (*) preceding the item number. These items are not appropriate for design review.

(2) To assist preventive medicine and other personnel in evaluating either the physical facilities, including equipment, in an existing food service facility or plans and specifications for new or renovated facilities. Items and issues are addressed as they relate to maintaining acceptable levels of cleanliness and food sanitation.

(3) With extensive remarks areas for the individual items and separate remarks areas for major sections.

b. The reference(s) for the specific items are noted in parenthesis below the item.

c. We suggest that you remove the checklists, make copies as needed, and return the original pages to this TG for future use.

CHECKLIST 1 - FLOORS

1. Are existing or proposed floor coverings structurally sound, non-slippery when wet, and easily cleaned? YES ___ NO ___

(NSF International Reference Guide, page 9)

2. Are floor coverings of approved materials? YES ___ NO ___

Note: Approved materials are listed in Table 1-1.

(NSF International Reference Guide, page 9)

3. Do floors in traffic areas have a non-slip texture? YES ___ NO ___

(NSF International Reference Guide, page 9)

4. Is U.S. Department of Agriculture (USDA)-approved sawdust substitute or butcherpaper used in butcher shops and/or meat cutting room6 only to provide a slip-resistant surface? YES ___ NO ___

If yes, list:

Where	Why	Condition
_____	_____	_____
_____	_____	_____
_____	_____	_____
_____	_____	_____
_____	_____	_____

(Military Standard (MIL STD)-903)

*5. Are -supplemental floor coverings, mats, or duckboards used?

YES ___ NO -

If yes, list locations: _____

(NSF International Standard 52)

6. Is supplemental flooring--

Serviceable?

YES ___ NO ___

NSF approved?

YES ___ NO ___

Readily removable?

YES ___ NO ___

(NSF International Standard 52)

7. Are the junctions between the floor and wall coved and sealed?

YES ___ NO -

Note: *This* can be accomplished by the use of cove &se tiles or continuous pour of sheet flooring *which is run up the wall and sealed,*

List locations with open floor to wall junctions: _____

(TB MED 530, para 6-7)

8. If the cove base is a flexible asphalt strip or asphalt tile, is the base of the wall or floor free of water damage or evidence of insect harborage?

YES ___ NO ___

Note: *Openings* as little as 1/16th of an *inch* can provide cockroach *harborage.*

If no, list location.6: _____

(TB MED 530, para 6-7)

9. Is- the cove base securely attached to the wall to prevent pest harborage? YES ___ NO ___

(TB MED 530, para 5-33d)

10. Is the cove base material compatible with material6 used for the walls and floor? YES ___ NO ___

(NSF International Reference Guide, page 9)

11. Floor drains. (See Checklist 5 - Sanitary Waste Disposal)

12. Service connections. (See Checklist 4 - Service Connections/Utilities; Checklist 5 - Sanitary Waste Disposal; and Appendix B)

General CMTS: _____

Table 1-1
Material finishes for floors

	Quarry Tile	Sealed Concrete	Poured Seamless	Hardwood (Wood Tile)	Indoor/ Outdoor Carpet
Kitchen	X	X	X		
Dry storage	X	X	X		
Scullery	X	X	X		
Serving	X	X	X		
Rest rooms	X		X		
Janitor closets	X	X	X		
Bar	X	X	X		
Butcher shop	X		X		
Dining areas					X
Admin office ⁶ and other non- food areas	X	X	X	X	X

Note: *Alternate* materials may be approved by the installation medical authority (IMA) provided that the required level of durability, cleanability, and safety can be met,

(NSF International Reference Guide, page 9, para 2-2, Table 1;
 TB MED 530, paras 6-3 and 6-4)

CHECKLIST 2 - WALLS

1. Are walls in sound condition? YES___ NO___

(Not broken from contact with carts or equipment; holes around pipes and other penetrations sealed.)

Note: Acceptable sealants include cement and durable caulk designed to resist moisture and insect and rodent entry.

If no, list locations: _____

(TB MED 530, paras 6-9 and 6-10)

2. Are walls free from any evidence of mildew or broken or chipped edges around pipes and electrical connections? YES___ NO___

If no, list locations: _____

(TB MED 530, para 6-14)

3. Are walls constructed from approved materials? YES___ NO___
(See Table 2-1.)

If no, list locations and deficiencies: _____

(TB MED 530, para 6-10)

4. If gypsum wallboard is used, is only water-sealed gypsum wallboard used on wood¹ or steel² studs in areas subject to moisture or high humidity³?

YES ___ NO -

Notes:

¹ Wood stud walls should be reported to the installation fire prevention personnel for their evaluation. Wood stud walls may be a violation of fire safety regulations.

² Absorbent wall materials will transfer moisture to steel studs resulting in corrosion. Water-sealed gypsum wallboard used for tile backing in bathrooms, kitchens, etc., does not present this problem.

³ Moisture or high humidity areas include: food preparation, serving line, pot and pan, dish washing, and scullery areas and other areas subject to-frequent cleaning or steam.

If no, list locations: _____

(TB MED 530, para 6-10)

5. Are concrete block walls used?

YES ___ NO ___

6. If used, are concrete blocks in good repair and finished to an easily cleanable surface, either faced with ceramic tile, skim plaster, or coated with an epoxy paint?

YES ___ NO ___

(TB MED 530, paras 6-10 and 6-11)

7. Do wall coverings used in dining areas provide sound absorption? YES ___ NO ___

*8. Are the conditions of any accent wall coverings including murals, sculptures, rugs and tapestries acceptable? YES ___ NO ___

If no, list locations _____

(TB MED 530, para 6-12)

9. Are wall coverings maintained in a clean, sanitary condition? YES ___ NO ___

(TB MED 530, para 6-10)

10. Are wall coverings constructed and maintained to prevent harborage for insects or rodents either inside or behind the coverings? YES ___ NO ___

Note: The optimal time to treat wall voids and other inaccessible spaces within the walls with built in pest control substances, such as boric acid and silica gel, is during renovation.

If no, list locations: _____

(TB MED 530, para 6-10)

11. Do exposed corners of glazed structural units, concrete masonry unit partitions, and columns subject to damage from portable food service equipment have protective guards not less than 72 inches above the finished floor? YES ___ NO ___

(TB MED 530, para 6-10)

12. Are items which attach to the walls and ceilings (for example, exhaust vents and ducts, lights, and shelving) designed and installed to be--

Easily cleaned?

YES___ NO -

Sealed or gaps eliminated to prevent pest harborage?

YES___ NO -

Note: Sealing must be thorough and 100 percent. One gap 1/16th of an inch can allow pest access to the harborage and decrease the ability to apply control measures. If an area cannot be completely sealed, it should be left open.

If no, list locations and type deficiencies:

(TB MED 530, para 6-12) .

Table 2-1

Wall materials and construction in food preparation, serving, scullery, warewashing, and other areas

Acceptable Materials*

Cooking and other high heat areas.

Stainless steel or aluminum

Other food preparation areas, dry storage, serving line, rest rooms, and janitor closet.

Glazed structural units (including glazed ceramic tile with impervious grout)

Plastic laminated panels

Drywall, taped and epoxy painted

Concrete block, filled and epoxy painted

Stainless steel or aluminum

Warewashing, mechanical and manual.

Glazed structural units

Concrete block, filled and epoxy painted

Stainless steel or aluminum

Unacceptable Materials

Open beam or wall stud construction**

Wood, plywood paneling

Unsealed drywall

* All walls and wall coverings must be light colored, nonabsorbent, and easily cleanable.

- * Open beams and other structural members may be acceptable in dining rooms, administrative offices, and patron entrances. If exposed, in dining rooms and patron entrances, these must be finished to provide a smooth, easily cleanable surface.

(TB MED 530, para 6-10; NSF International Reference Guide, page 10)

List any deficiencies with wall coverings or construction: _____

CHECKLIST 3 - CEILING

1. Are ceilings in food service facilities--

Structurally sound?

YES ___ NO ___

Light colored, nonabsorbent, and easily cleanable?

YES ___ NO ___

If no, list locations and deficiencies: _____

(TB MED 530, paras 6-9 and 6-10)

2. Are ceilings in high humidity areas composed of materials which are resistant to moisture?

YES ___ NO ___

Note: Table 3-1 contains examples of ceiling material which are water resistant and/or easily cleanable.

If no, list locations and deficiencies: _____

(NSF International Reference Guide, page 11)

3. Is there no evidence of--

Water damage?

YES ___ NO ___

Tiles or panels delaminating?

YES ___ NO ___

Walls or ceilings water stained?

YES ___ NO ___

Pest activity?

YES ___ N O -

Note: Water damage can have several sources including: roof or overhead plumbing leaks, inadequate ventilation to control humidity, poor installation, or improper materials.

If yes, list locations and possible causes: _____

(TB MED 530, paras 5-33, 6-9, and 6-10)

Table 3-1

Ceiling materials and construction in food preparation, serving, scullery and warewashing areas

Acceptable Materials

Plastic coated fiber board .	Glazed surface
Metal clad panels	Plastic laminated panels
Drywall, taped and epoxy painted	Nonabsorbent acoustical tiles

Unacceptable Materials

Open beam, rafters or joists construction*

Fiberglass panels	Wood
Unsealed drywall	Plywood

- Open beams and other structural members may be acceptable in dining room, administrative offices, and patron entrances. If exposed, these must be finished to provide a smooth, easily cleanable surface,

(NSF International Reference Guide, page 11)

CHECKLIST 4 - SERVICE CONNECTIONS/UTILITIES

1. Are openings in floors and walls for utility/ service/soda line connections sealed with mildew resistant caulking to prevent entrance of pests or moisture? (See Appendix B.) **YES**___ **NO**___

List areas of possible moisture and or pest damage: _____

(TB MED 530, para 6-14; NSF International Reference Guide, page 76, figure 3-6))

2. Is sealing smooth, flush with surface, and easily cleaned so that it DOES NOT trap dirt and debris? **YES**___ **NO**___

(TB MED 530, paras 6-12 and 6-14)

3. Are protective sleeves, metal face plates, or conduits--

Used where pipes and service lines pass through walls and floors? **YES**___ **NO**___

Sealed to prevent insects from harboring in them? **YES**___ **NO**___

(NSF International Reference Guide, page 76)

4. Are utility lines sealed or protected where they enter the facility? **YES**___ **NO**___

(TB MED 530, para 6-14)

5. Do shelf attachments, electrical lines or plumbing, penetrate interior, non-load bearing walls? **YES**___ **NO**___

- 6. If yes, are these penetrations sealed with mildew resistant caulking to prevent harborage inside the wall or behind brackets and interfaces where sinks, shelves, and cabinets meet the wall?

YES ___ NO ___

Note: *Examples of acceptable sealants include: cement, mildew resistant caulk, and a combination of metal sleeves and caulk.*

Sealing must be thorough and 100 percent. One gap 1/16th of an inch can allow access to t&e harborage and decrease the ability to apply control measures. If an area cannot be completely sealed, it should be left open.

(TB MED 530, para 6-14)

- 7. Are there any penetrations of the firewalls?

YES ___ NO ___

- 8. If yes, are these penetrations sealed?

YES ___ NO ___

(TB MED 530, para 6-14)

- 9. Is there any evidence of rodent or insect harborage?

YES ___ NO ___

Identify locations of any wall, floor, or ceiling penetrations that are not sealed or could allow pest harborage: _____

General Note: *In most food service operations, extending the utilities down from the ceiling is preferred to bringing the utilities from the wall or floor.*

- 10. Are there any exposed pipes along floor or wall?

YES ___ NO ___

- 11. Are pipes and service lines a minimum of 6 inches above the floor and 1 inch from walls and adjacent lines or pipes?

YES ___ NO ___

(TB MED 530, para 6-15)

12. IS there adequate clearance for cleaning around pipes and utility lines?

YES ___ NO ___

Note: Check especially under and behind work tables and cabinets.

If no, list locations and deficiencies: _____

(TB MED f30, para 6-15)

13. If piping is subject to sweating, or if it is a burn hazard, is it adequately insulated or guarded?

YES ___ NO ___

If no, list locations and deficiencies: _____

(NSF International Reference Guide, page 76)

14. Is insulation insect proof.?

YES ___ NO ___

(TB MED 530, para 6-14)

General CMTS: _____

CHECKLIST 5 - SANITARY WASTE DISPOSAL

1. Are sanitary sewer lines and connections at least equal, in diameter, to the waste connection on the equipment? YES ___ NO ___

If no, list locations and deficiencies: _____

(NSF International Reference Guide, page 76)

- *2. Are waste lines, inside or outside the facility, free of any evidence of back up? YES ___ NO ___

3. Are there any grease traps? YES ___ NO ___

4. Are these grease traps outside the dining facility? YES ___ NO ___

(TB MED 530, para 5-14)

5. Are the grease traps easily accessible? YES ___ NO ___

List locations and deficiencies: _____

(TB MED 530, para f-141)

General *CMT*. *TB MED 530* requires grease traps to be located outside the building for new construction and renovations that include existing grease traps.

6. Are there floor drains for floors that are water flushed for cleaning or which receive liquidwaste from equipment which can discharge onto the floor? YES ___ NO ___

7. Are floors graded to drain to prevent standing water? YES ___ NO ___

(TB MED 530, para 6-6)

8. Are the floor drains sealed/caulked to prevent moisture from getting between the floor and the drain?

YES ___ NO ___

(TB MED 530, para 6-6)

9. Are floor drains easily accessible for cleaning?

YES ___ NO ___

10. Are waste discharge, condensate pipes, carbon dioxide (CO₂) and pressurized beverage dispensing lines¹ elevated a minimum of 6 inches above the equipment² underneath or floors?

YES ___ NO -

Notes:

¹ Where these lines extend horizontally beyond the equipment, appropriate support must be provided to maintain this elevation.

² Examples of equipment include hot/cold food tables, mechanical dishwashing and and potwashing units, ice machines, and carbonated beverage dispensing units.

(TB MED 530, para 6-6)

CHECKLIST 6 - BACK SIPHONAGE/BACKFLOW PREVENTION

1. Are potable water connections protected against backflow or back siphonage? (See Appendix C.) YES ___ NO ___

Note: Backflow prevention devices must be installed on all fixtures and equipment where an air gap of 2 times the diameter of the water supply inlet is not provided between the water supply inlet and the flood level of the fixture/equipment.

Examples of equipment and fixtures which should be inspected, but are often overlooked, include: outside hose bibs; fixed food processors; carbonated beverage dispensers; dishwashers; janitor sinks with hoses attached; and equipment with clean-in-place (CIP) systems.

(TB MED 530, para 5-13)

2. Except for properly trapped open sinks, are there any direct connections between any equipment drains and the sanitary sewer? YES ___ NO ___

If yes, list location and type connection: _____

(TB MED 530, para 5-13)

Note: See specific checklists for backflow prevention including: Checklist 17 - Garbage and Refuse and Checklist 18 - Water Supply.

CHECKLIST 7 - BAR TYPE SINKS AND SODA FOUNTAINS

1. Are bar type sinks and soda fountains properly vented? **YES** ___ **NO** ___

Exception: When sinks in bars, soda fountains, and counters are located so that the traps serving the sinks cannot be vented, the sink drains must discharge through an air gap or air break into a floor drain, sink, or hopper that is properly trapped and vented.

List location and description of any improperly vented bar sinks and soda fountains: _____

2. Are water lines which serve carbonated beverage machines provided with correct backflow prevention? (See Appendix D for suggested types of backflow prevention devices.) **YES** ___ **NO** ___

Note: Mention of suggested sources does not imply endorsement by the U.S. Army.

(TB MED 530, para 5-13)

CHECKLIST 8 - FOOD-WASTE GRINDERS

1. Are food-waste grinders--

Trapped separately from any other fixtures or sink compartments? **YES** ___ **NO** ___

Easily cleanable¹, and kept clean? **YES** ___ **NO** ___

Installed so that they **YES** ___ drain through a grease trap²? -

Notes:

¹ *Kitchen personnel should demonstrate the ability to clean the grinder, including any disassembly.*

² *Food-waste grinders must not be connected to, or discharge through, a grease trap or grease interceptor.*

2. If food-waste grinders have internal water supply, is the potable water supply protected by a backflow or back syphon prevention device? **YES** ___ **NO** ___

List locations and deficiencies: _____

(TB MED 530, para 5-15)

CHECKLIST 9 - LIGHTING AND ELECTRICAL CONNECTIONS

The lighting levels must be evaluated during each operating shift. Food service facilities can rely on natural lighting during daylight hours, but adequate supplemental lighting is required for facilities which operate on multiple shifts. This is especially important for after hours cleaning crews.

1. Are lighting levels adequate to allow sanitary food service? YES ___ NO ___

Note: Lighting in existing food service facilities may be dramatically improved by cleaning or relocating light fixtures, moving shel viny, cleaning or resurfacing walls and ceilings with light colors.

2. Table 9-1 lists the lighting levels required in food service operations.

Table 9-1

Lighting levels required in food service operations

<u>in foot candles (fc)</u>	<u>illumination level</u>
	<u>nd f</u>

Measured at work level

All food preparation surfaces	50
Equipment and utensil washing work levels	50

Measured 30 inches from the floor

Throughout food preparation, at serving line, and in warewashing work areas	30
Throughout storage areas including: utensil, equipment, and food storage	20
Lavatories, toilets, and locker rooms	20
In dining room, during clean operations	20
Inside walk-in refrigerators, freezers, and ice storage areas	10

(TB MED 530, para 6-18)

3. List Areas with inadequate lighting.

<u>Area</u>	<u>Lighting level</u>	<u>Comments</u>
_____	_____	_____
_____	_____	_____
_____	_____	_____
_____	_____	_____
_____	_____	_____

4. Are protective shields, plastic coated fluorescent bulbs, or shatter-proof bulbs used in--

- Food preparation areas? YES ___ NO ___
- Food service and display areas? YES ___ NO ___
- Storage areas for unpacked food? YES ___ NO ___
- Utensil and equipment cleaning and storage areas? YES ___ NO ___

(TB MED 530, para 6-19)

5. List any areas with unprotected lighting.

<u>Area</u>	<u>Type lighting</u>	<u>Comments</u>
_____	_____	_____
_____	_____	_____
_____	_____	_____
_____	_____	_____
_____	_____	_____

6. Are ground-fault circuit interrupters (GFCIs) used in wet locations? YES ___ NO -

Note: See **Glossary** for definition of wet locations. Refer **this item to the supporting safety office if non-GFCIs** are noted in wet locations.

(AR 420-43, para 4-3(d))

CHECKLIST 10 - VENTILATION SYSTEMS

All ventilation systems in dining facilities must comply with the applicable standards of the American Society of Heating, Refrigeration, and Air Conditioning Engineers (ASHRAE) and the American Conference of Governmental Industrial Hygienists (ACGIH) and applicable National Fire Protection Association (NFPA) Codes.

1. Are the following areas provided with general or local exhaust ventilation (LEV) systems? If the food service facility is located in a building with a common ventilation system, is the air exhausted directly outside?

<u>Location</u>	<u>Type General/LEV</u>	<u>Exhaust system</u>	<u>Exhaust to outside</u>
Dish washing area(s)*	____/____	YES ___ NO ___	Y E S ___ N O -
Pot and pan washing*	____/____	YES ___ NO ___	YES ___ NO ___
Food preparation, processing, and serving areas*	____/____	YES ___ NO ___	YES ___ N O -
Dressing or locker rooms	____/____	YES ___ NO ___	YES ___ NO -
Bathrooms	____/____	YES ___ No ___	YES ___ NO ___
Indoor garbage or refuse storage	____/____	YES ___ NO ___	YES ___ NO ___

• LEV is required in areas where steam, high humidity, and grease or smoke are released

(TB MED 530, paras 6-20a and b)

2. Do the workers or managers of the facility note any problems with--

Excess odors? YES ___ NO ___

Buildup of smoke from grills? YES ___ NO ___

Steam or condensation on walls or equipment?

YES ___ NO ___

Slow drying of dishes and pots and pans (especially when the wash and rinse temperatures* meet the requirements in TB MED 530, paras 4-28 and 4-29)?

YES ___ NO ___

Inadequate air movement or drafts?

YES ___ NO ___

Buildup of grease on equipment, inside exhaust canopy hoods, or on grease filters²?

YES ___ NO ___

Notes:

¹ *When chemical sanitizer(s) are used, the drying time is generally longer than for hot water sanitized dishes.*

² *You must separate inadequate housekeeping from mechanical deficiencies when evaluating kitchen exhaust hoods and grease filters.*

If yes, list locations and description of problem(s): _____

3. Is there any indication of insufficient make up air--

Do exhaust fans change pitch when windows or doors are opened or closed?

YES ___ No ___

Are doors initially hard to open then become easier when air pressures equalize?

YES ___ NO ___

4. Is there any other evidence of inadequate ventilation? YES ___ NO ___

If yes, list locations and description of problem(s) (areas already identified in para 3 need not be restated): _____

5. Are the pot and pan washing areas and dish washing areas provided a minimum of 20 air changes per hour? YES ___ NO ___

Note: To determine the air changes per hour for pot and pan and dish washing areas, measure the total air exhausted from the area, that is: measure the general room exhaust and any LEV systems. Add these together and divide this number by the warewashing area volume to determine the total air changes for the area. Air exhausted from these areas must not be recirculated.

Example:

General room exhaust = 3,000 cubic feet per minute (cfm)
 Exhaust from hood(s) = 2,000 cfm
 Total exhaust = 5,000 cfm
 x 60 minutes
 Total air exhaust = 30,000 cubic feet per hour

Divide total air exhausted per hour by volume of the warewashing area.*

30,000 cubic feet per hour
 + 5,000 cubic feet room volume*
 = 6 air changes per hour (exhaust)

* Warewashing areas are frequently open to adjoining areas. The room and local exhaust should be sufficient to prevent steam, moisture, and odors from entering any adjoining areas.

(TB MED 530, paras 6-20 and 6-21)

6. Evaluation of existing LEV systems. Existing LEV systems are evaluated for--

- 0 Capture velocity (CV).
 - σ velocity.
 - Exhaust air volume.
 - Duct velocity.
 - Fire protection.

Note: For definitions of the above terms, see the Glossary, Section II.

7. Criteria.

a. The most important criteria for existing kitchen LEV systems are:

- CV.
- Duct velocity.
- Cleanability.
- Fire protection.

b. Existing serviceable LEV systems are not replaced for the purpose of meeting the design criteria provided the existing system(s) meet OR can be modified to meet the NFPA Standard 96 and the minimum CV at the cooking surface listed in Table 10-1.

Table 10-1
Minimum capture velocity at cooking surface

Type equipment	Minimum CV
Non-grease producing (e.g., steam kettles, stock pots, warewashing areas, ranges, and small griddles)	50 fpm
Grease producing (e-g., fryers, pressure fryers, and medium to large griddles)	75 fpm
High heat or smoke producing (e-g., charcoal grills, upright broilers, and open barbecue pits)	150 fpm

(TB MED 530, para 6-21)

C: Kitchen equipment is frequently grouped under a single large canopy hood, either over a cooking island or against a wall. When this is done, the effectiveness of the system can be evaluated by observing the heat waves, steam, smoke, and grease rising from the cooking surfaces. The CV should be measured at each piece of cooking equipment and for existing exhaust systems and compared against the minimum CV in Table 10-1.

- (1) If the system, based on your visual observation, does not capture the steam and grease released from the cooking surfaces, cooking pots, etc.; or the CV measured at the cooking equipment are below the minimum CV in Table 10-1, the actual quantities of air exhausted from these canopy hoods must be determined. The ACGIH manual, *Industrial Ventilation, A Manual of Recommended Practice*, should be used to evaluate the effectiveness of the system(s).

(ACGIH Manual, plates VS-910 thru VS-915)

- (2) Duct velocity.

- (a) Examine the interior surfaces of the LEV hoods and duct work.

Is there a buildup of grease, particularly in the duct and in the hood behind any grease filters?

YES ___ NO ___

- (b) Determine the velocity of the exhaust air within the duct. Follow procedures in the ACGIH manual for measuring average duct velocity^{1,2}. Determine duct velocities with grease filters and other similar equipment in place.

Notes:

¹ *The minimum duct velocity for kitchen exhaust systems transporting grease laden air is 1,500 fpm. Low duct velocities will allow the grease to settle out of the exhaust air and coat the duct. This film or grease is highly flammable.*

² Maximum duct velocities are given in the ACGIH plates. High duct velocities, above 3 to 4,000 fpm, can cause excess noise, high turbulence within the duct and excessive energy requirements.

(NFPA Standard 96, para 5.2)

List locations and ventilation system deficiencies: _____

Note: Include drawings and applicable measurements.
Additional sheets may be attached.

CHECKLIST 11 - GREASE REMOVAL SYSTEMS

1. Grease filters **and** other grease **removal systems.**

a. Are grease filters installed at an angle between 45 and 60 degrees from the horizontal? YES ___ NO ___

(TB MED 530, para 6-22; ACGIH manual plate VS-910)

b. Are filters tight fitting* and firmly held in place? YES ___ NO ___

(TB MED 530, para 6-22)

c. Are filters the correct type and size* for the exhaust hood? YES ___ NO ___

** Note: The grease filters should fit snugly in the filter rack(s). There should be no gaps between filters or between the filter(s) and the filter rack.*

d. Are filters, ducts, hoods, etc. cleaned on a regular basis*? YES ___ NO ___

• *Deficiencies in operations grease removal systems may be due to a combination of problems:*

- *Inadequate CV will cause the grease to settle on the hood and duct surfaces. This will require extra cleaning.*
- *Inadequate frequency of grease filter cleaning will cause a buildup of grease on this filter surface. This buildup restricts air flow through the filter and CV and duct velocities.*

- Where grease filters have been removed from hoods, or they do not fit tightly enough, grease and entrained dust will build up on air movers, screens, vents and louvers. This build up greatly reduces the volume and velocity of air moving through the hoods.

Evaluators should determine if inadequate ventilation is due to inadequate operation and/or maintenance of the system.

If no, list locations and potential problems:

Note: For detailed information on the proper design of hoods with grease filters, refer to the Design of Grease Filter Equipment Kitchen Exhaust Systems. Limited copies are available from the USAEHA Sanitation and Hygiene Program at DSN 584-2488 or commercial 410-671-2488.

2. Drip pans.

- | | |
|--|----------------|
| a. Are there drip pans at the edge of the hood to catch grease? | YES ___ NO ___ |
| b. Are the drip pans removable for cleaning? | YES ___ NO ___ |
| c. Do the drip pans drain to a collection point? | YES ___ NO ___ |
| d. If the grease drains into a collection container, is the container 1 gallon capacity or less? | YES ___ NO ___ |

(TB MED 530, para 6-22)

CHECKLIST 12 - GENERAL VENTILATION

- 1. Are all exhaust system outlets located away from any air intakes? YES ___ NO ___

Note: Refer to ASHRAE Handbook of Fundamentals and ACGIH Industrial Ventilation Manual for required separation between exhaust outlets and air intakes.

- 2. Are air ducts provided with clean outs? YES ___ NO ___
(ASHRAE Handbook of Fundamentals and ACGIH Industrial Ventilation Manual)

- 3. Is ventilation designed with the kitchen area under negative pressure with respect to other areas? YES ___ NO -

Note: The total exhaust for the kitchen should be 10 percent greater than the supply, but not exceed 0.02 inches water gage air pressure differential to adjoining areas.

(ASHRAE Fundamentals Handbook; ACGIH Ventilation Manual; and NFPA Std 96, para f-3)

- 4. Are separate air handling units provided for--
 Kitchen area? YES ___ NO ___
 Dining area? YES ___ NO ___
 Office areas? YES ___ NO ___

(ASHRAE Fundamentals Handbook and ACGIH Industrial Ventilation Manual)

List any deficiencies in general ventilation: _____

. CHECKLIST 13 - BATHROOMS AND HAND WASHING FACILITIES

1. Are an appropriate number of facilities (i.e., toilets, urinals, and sinks) provided based on the number of employees? YES ___ NO ___

Note: Number of facilities must comply with Occupational Safety and Health Administration (OSHA) standards. See Table 13-1.

(Concept of Design and Operations for Army Dining Facilities, chapter 9)

Table 13-1

Bathroom facilities

Number of employees	Minimum number of water closets*
1-15	1
16-35	2
36-55	3
	4
56-100	5
111-150	6
Over 150	**

* Where toilet facilities will not be used by women, urinals may be provided instead of water closets, except the number of water closets in such cases shall not be reduced to less than 2/3 the minimum specified.

** Provide 1 additional fixture for each additional 40 employees.

(29 CFR 1910,141, Table J-1)

2. Are separate facilities available for patrons and staff?

YES ___ NO -

Note: Separate staff and patron facilities are required for new and renovated food service facilities, except for Army and Air Force Exchange Service (AAFES) fast food facilities.

(TB MED 530, paras 5-17 and 5-23)

3. Are toilet facilities installed and constructed to allow for easy cleaning of all stalls, urinals, and fixtures?

YES ___ NO ___

(TB MED 530, para 5-18)

4. Can cleaning personnel easily clean around fixtures, particularly behind commodes and in stalls?

YES ___ NO ___

5. Are floors easily cleanable and in good repair?

YES ___ NO ___

(TB MED 530, para 5-18)

6. Are tight-fitting, self-closing doors provided for toilet facilities?

YES ___ NO -

(TB MED 530, para 5-19)

7. Are facilities located so that they DO NOT open directly into--

Areas where food is stored, prepared, or served?

YES- NO ___

Utensil washing areas?

YES ___ NO ___

(TB MED 530, para f-19)

List any deficiencies with toilet facilities: _____

CHECKLIST 14 - BATHROOM AND TOILET FACILITY VENTILATION

1. Does exhaust ventilation provide at least 10 air changes per hour? YES ___ NO ___

(ASHRAE std 62-1989)

2. Is exhaust vented directly to the outdoors and not into a common exhaust duct or return air duct for the building ventilation system? YES ___ NO ___

Note: Recirculating exhaust air from toilet facilities is not permitted.

(ASHRAE std 62-1989)

3. Is adequate make-up air provided to bathrooms by supply air ducts or louvers in the entrance doors? YES ___ NO ___

(ASHRAE std 62-1989)

List any deficiencies in bathroom facility ventilation: _____

CHECKLIST 15 - EMPLOYEE FACILITIES

1. Is one half-size wall locker provided for each employee? YES ___ NO ___
(Concept of Design and Operations for Army Dining Facilities, chapter 9)
2. Are separate locker rooms provided for male and female employees? YES ___ NO ___
(Concept of Design and Operations for Army Dining Facilities, chapter 9)
3. Are locker rooms contiguous to latrines? YES ___ NO ___
(Concept of Design and Operations for Army Dining Facilities, chapter 9)
4. Are latrines separate for male and female employees? YES ___ NO ___
(Concept of Design and Operations for Army Dining Facilities, chapter 9)
5. Is minimum ventilation in locker rooms/rest rooms available, at least 10 air changes per hour? YES ___ NO ___
(TB MED 530, para 5-22; Concept of Design and Operations for Army Dining Facilities, chapter 9)
6. Is all air from the rest rooms exhausted directly to the outdoors? YES ___ NO ___
(TB MED 530, para 5-22; Concept of Design and Operations for Army Dining Facilities, chapter 9)
7. Are the rest rooms under negative pressure relative to the adjoining locker rooms and all other areas? YES ___ NO ___
(Concept of Design and Operations for Army Dining Facilities, chapter 9)

List locations and deficiencies: _____

CHECKLIST 16 - HAND WASHING FACILITIES

Hand washing design requirements apply throughout the food service facility.

1. Are hand washing facilities provided in convenient locations, for use by food service staff? YES ___ NO ___

(TB MED 530, para 5-23)

2. Are hand washing facilities provided-- Within the food preparation area? YES ___ NO ___

Behind or adjacent to serving areas? YES ___ NO ___

Within utensil washing areas? YES ___ NO ___

Within bathrooms or vestibules? YES ___ NO ___

(TB MED 530, paras 5-23 and 5-24)

3. Are sinks designated for hand washing NOT USED for preparing food or washing equipment? YES ___ NO ___

(TB MED 530, para 5-24)

4. Are hand washing sinks provided with hot and cold or tepid running water? YES ___ NO ___

(TB MED 530, para 5-25a)

List any food preparation or utensil, warewashing areas which do not have readily accessible hand washing facilities.

Table with 2 columns: Location, Function (e.g. salad prep,). Includes several blank rows for data entry.

5. Does each hand washing station have--

Adequate hot water (110 °F to 120 °F)? YES___ NO-

(Concept of Design and Operations for
Army Dining Facilities, Army Troop
Support Agency)

A soap dispenser? YES___ NO-

(TB MED 530, para 5-25a)

A disposable towel dispenser? YES___ NO-

(TB MED 530, para 5-25b)

A waste disposal container? YES___ NO___

(TB MED 530, para 5-25b)

*Note: Ideal hand washing stations include
foot, knee, or elbow operated faucets.*

CHECKLIST 17 - GARBAGE AND REFUSE STORAGE

1. Axe compactor-type units on concrete pads? YES ___ NO ___
 (TB MED 530, para 5-26d)

2. Is the concrete pad provided with a drain which connects to the sanitary sewer system to prevent liquids from contaminating the ground or entering the storm sewer systems? YES ___ NO ___
 (TB MED 530, para 5-26c)

3. Are bulk collection dumpsters equipped with a drain for washing and cleaning? YES ___ NO ___
 (TB MED 530, para 5-26)

4. Are the bulk collection dumpsters' drains either plugged or **screened between** cleaning to prevent pest entry? YES ___ NO ___
 (TB MED 530, para 5-26)

5. Are there accessible hose bibs with backflow prevention devices for cleaning dumpsters and adjoining areas? YES ___ NO ___
 (TB MED 530, para 5-13)

6. Are outdoor garbage and refuse containers--
 - Located on a smooth surface of non-absorbent material, **such as concrete**? YES ___ NO ___
 (TB MED 530, paras 5-26a and 5-27d)

 - Adjacent to receiving areas, but no closer than 50 feet to the facility entrance doors? YES ___ NO ___
 (TB MED 530, para 5-26a)

Note: Containers/dumpsters stored outside the establishment will be provided with tight-fitting lids, doors, or covers and kept covered at all times.

7. Are internal garbage refuse rooms--

Easily cleanable and constructed of non-absorbent materials?

YES ___ NO ___

(TB MED 530, para 5-27b(1))

Insect and rodent resistant?

YES ___ NO ___

(TB MED 530, para 5-27b(3))

8. Are utility sinks or floor utility sinks available for filling and emptying mop buckets?

YES ___ NO ___

(TB MED 530, para 6-17)

9. Are facilities available to air dry mops?

YES ___ NO ___

CHECKLIST 18 - WATER SUPPLY

1. Do all food preparation sinks provide hot and cold running water? YES ___ NO ___

(TB MED 530, para 5-2)

2. Is potable water provided for culinary purposes? YES ___ NO ___

(TB MED 530, para 5-2)

3. Does the flow pressure and volume of water supplied to fixtures--

Comply with Appendix C of the latest edition of the Building Officials' & Code Administrators' (BOCA) Basic Plumbing Code? YES ___ NO ___

(NSF International Reference Guide, page 15)

Meet the *minimum* and *maximum* pressure and volume requirements for all fixtures and equipment? YES ___ NO ___

Note: Consult the equipment data plate(s) and specification sheets; especially for mechanical pot and pan and dish washing machines, booster heaters, and backflow prevention devices, for minimum and maximum operating pressures, flow rates and water line sizes.

(NSF International Reference Guide, page 15)

4. Are water supply lines for hot water generating equipment sized based on the manufacturer's recommendation for connection to the specific pieces of food service equipment? (See Appendix E.) YES ___ NO ___

(NSF International Reference Guide, page 85)

5. Can the minimum water pressure requirements be met when the majority of the equipment is operating?

YES ___ NO ___

(NSF International Reference Guide, page 15)

6. Are water heaters sized to provide the required flow rate and volume of the final rinse based on the flow rate of the warewashing machine?

YES ___ NO ___

(NSF International Reference Guide, page 85)

7. Are warewashing *machines* equipped with booster heaters supplied hot water at a minimum of 140 °F?

YES ___ NO ___

Note: Commercial booster *heaters* are designed to raise the *water temperature* a *maximum* of 40 °F.

(TB MED 530, para 5-6a)

8. Are water lines and water coolers free from lead and lead solder?

YES ___ NO ___

(NSF International Reference Guide, chapter 5; and NSF Manual on Installation of **Food Service Equipment**)

Note: Additional guidance for hot **water** generating equipment is contained in Checklist 24 - Hot Water Generating **Equipment**.

CHECKLIST 19 - FOOD SERVICE EQUIPMENT (General Requirements)

1. Are food service equipment or supplies NOT located under exposed or unprotected sewer or water lines? YES ___ NO ___

Note: With the exception of automatic fire protection sprinkler system lines, there should be no food service equipment or utensils, food products, or supplies (including paper products) stored under exposed or unprotected water or sewer lines, in open stairwells, or in elevator shafts.

(TB MED 530, para 4-20)

2. Does food service equipment meet NSF International standards? YES ___ NO-

(TB MED 530, para 4-2; NSF International Reference Guide, page 69)

Note: *Equipment manufacturers can demonstrate that their equipment meets applicable NSF International standards--*

- m by the NSF mark on the equipment and listing in the "NSF Annual Listing" for the year the equipment was manufactured,*
- through t&e NSF one-time listing program, or*
- through certification by an independent laboratory, acceptable to The Surgeon General.*

Determining if food service equipment in older facilities meets NSF International standards may be difficult. Look for the blue NSF mark with a raised manufacturer's identification on the mark or the NSF mark on the equipment data plate.

If the equipment was certified by either the NSF one-time listing or by the independent laboratory, this may be on file at the facility.

Any unserviceable equipment must be replaced, regardless of whether or not it met the NSF International standards.

List all equipment which does not meet NSF International standards or is unserviceable.

Equipment	Location	Comments
_____	_____	_____
_____	_____	_____
_____	_____	_____
_____	_____	_____

(TB MED 530, para 4-36)

3. Is table-mounted equipment--

Sealed to a table or counter or elevated to provide at least a 4-inch clearance between the equipment and the table or counter for cleaning?

YES ___ NO ___

(TB MED 530, para 4-21a(1))

Installed to facilitate cleaning of the equipment and adjacent areas?

YES ___ NO ___

(TB MED 530, para 4-21a(2))

Portable, small, or light enough (65 to 70 pounds) to be moved by one person?

YES ___ NO ___

(TB MED 530, para 4-21b)

4. Is portable equipment provided with utility connections that are quick-disconnect or flexible to permit moving for cleaning?

YES ___ NO ___

(NSF International Reference Guide, page 74)

List locations and deficiencies: _____

5. Does floor mounted equipment meet one of the standards listed below? To indicate the standard met, mark the appropriate "YES" column.

Equipment is sealed directly to the floor around the perimeter of the equipment. (See Appendix F, figures F-1 and F-2.)

YES ___ NO ___

(TB MED 530, para 4-22; NSF International Reference Guide, page 73, figures 3-1 and 3-2)

Equipment is installed on a raised platform of concrete or other smooth masonry. (See Appendix F, figure F-3.)

YES ___ NO -

(TB MED 530, para 4-22; NSF International Reference Guide, page 74, figure 3-3)

Equipment is elevated on legs with at least a 6-inch clearance.

YES ___ NO -

(TB MED 530, para 4-22c)

Equipment is sealed to adjacent equipment, walls, or ceiling, unless sufficient space is provided for easy cleaning above, behind, and between each piece of equipment and the walls and ceiling. (See Appendix F, figure F-4.1)

YES ___ NO ___

Note: *If t&e equipment is not sealed and there is insufficient space provided for cleaning, the deficiencies must be corrected or the equipment must be made movable.*

(TB MED 530, para 4-22; NSF International Reference Guide, page 75, figure 3-5)

6. Is wall-mounted equipment--

Installed on a supporting wall in such a way as to prevent the collection of liquid waste and debris and insect harborage between the wall and equipment?

YES ___ NO ___

(NSF International Reference Guide, page 74c)

Provided with a 6-inch clearance between the lowest horizontal portion of the equipment and the floor? (See Appendix F, figure F-4.)

YES ___ NO ___

(NSF International Reference Guide, page 75, figure 3-5)

7. Does wheeled equipment requiring utility connections have either quick-disconnects or sufficient length flexible utility connections to permit moving for cleaning?

YES ___ NO ___

Note: *Wheeled equipment does not have to meet the installation clearances and other accessibility requirements of fixed equipment.*

(NSF International Reference Guide, page 74f)

CHECKLIST 20 - MACHINE WAREWASHING

This section applies to mechanical dish washing and mechanical pot and pan washing operations. R-separate checklist (Checklist 21) is included for &&rewashing machines which rely on a chemical sanitizer for final rinse.

1. Do the wash, rinse, and final rinse pressures meet manufacturer's minimum and maximum pressure requirements? (The pressure for the final rinse must be between 15 and 25 pounds per square inch (psi)².)

YES___ NO___

Notes:

- ¹ Pressures are measured when the machine is operating.
- ² If pressure exceeds 25 psi or the manufacturer's recommendation, a flow control valve or a pressure reducing valve must be installed. If the pressure is below 15 psi, a booster pump should be installed. The booster pump flow volume and pressure must meet equipment flow requirements. The pressure should be adjusted to 20 psi.

(TB MED 530, para 4-29; NSF International Reference Guide, page 81)

2. Is backflow prevention provided to protect against back siphonage?

YES___ NO___

(NSF International Reference Guide, page 81)

3. Are backflow prevention devices on 180 °F water lines labeled for use with high water temperatures?

YES___ NO___

(See manufacturer's catalog)

4. Are atmospheric and spring loaded vacuum breakers installed at least 6 and 12 inches, respectively, above the highest warewashing machine water line?

YES ___ NO-

(NSF International Reference Guide, pages 81-83)

5. Are NO valves installed between the backflow prevention device and the warewasher?

YES ___ NO ___

Note: Flow or pressure control valves must not be installed between an atmospheric vacuum breaker and the warewasher water distribution system (spray arms).

(NSF International Reference Guide, page 82)

6. If steam is used to heat water, are strainers provided upstream from the control valve? (See Appendix E.)

YES ___ NO ___

(NSF International Reference Guide, pages 81-82, figure 4-1)

7. Is there a steam shut-off valve provided near the warewashing machine?

YES ___ NO ___

(NSF International Reference Guide, page 82)

8. If gravity condensate return lines are required, do the return lines have a slope of 1/4 inch per foot?

YES ___ NO ___

(NSF International Reference Guide, page 82)

9. Are steam supply lines, steam valves, and condensate valves and final 180 °F rinse water lines insulated to protect from burns and heat loss?

YES ___ NO ___

(NSF International Reference Guide, pages 82 and 88)

10. Is the insulation insect proof to prevent harborage?

YES ___ NO ___

(TB MED 530, para 6-14)

11. Are there adequate drain boards and storage areas for holding soiled dishes, utensils, and pots and pans, and for air drying and storing clean dishes, utensils, and pots and pans?

YES ___ NO ___

(TB MED 530, para 4-29f)

12. Does hot water supplied for wash, rinse, and final rinse meet manufacturer's requirements?

YES ___ NO ___

(Individual equipment specifications)

List locations and deficiencies for mechanical warewashing system or equipment: _____

13. Is the flow of soiled dishes situated so that it DOES NOT intersect with the flow or storage of clean dishes, minimizing the potential for cross contamination?

YES ___ NO ___

(TB MED 530, para 4-32)

CHECKLIST 21 - CHEMICAL SANITIZING - WAREWASHING MACHINES

Warewashing machines, including undercounter glass washing machines in bars or fast food operations, which use chemical final rinse sanitizer, must meet the following specific requirements.

- 1. Is wash water temperature 120 °F? YES ___ NO ___
- 2. Is chemical sanitizer automatically dispensed? YES ___ NO -
- 3. Is there an alarm on the chemical dispensing system to indicate when the chemical feed is interrupted? YES ___ NO -

Note: The alarm should be checked to ensure it is functioning properly. The chemical dishwasher manufacturer's operating manual may have the correct test procedure. If not, empty the chemical reservoir and check if the alarm activates while t&e dishwasher is operating.

- 4. Are there timed cycles for wash and chemical rinse? The manufacturer determines the specific time for each cycle. These timed cycles are part of the NSF International approval. YES ___ NO ___

Note: The cycles should be timed. Deviation from the manufacturer's cycle times could indicate improper adjustment or excessively worn components such as the chains and sprockets, This also voids the NSF International listing.

- *5. Is the correct concentration of chemical sanitizer in contact with the utensils and equipment being sanitized? YES ___ NO ___

Note: The concentration of chemical sanitizer in t&e final rinse must be determined using an appropriate chemical test kit. If the concentration is below that specified, t&e equipment must be repaired or replaced.

6. Do chemical sanitizing machines meet requirements of NSF International Standard 3?

YES ___ NO ___

Note: Checklist 19 contains guidance required to determine if the chemical sanitizing warewasher meets NSF International standards.

List locations and deficiencies noted with chemical sanitizer warewashing machines: _____

(TB MED 530, para 4-29)

CHECKLIST 22 - MANUAL WAREWASHING

1- Is there at least a three-compartment sink, with hot and cold potable water supplied to each compartment, provided for manual warewashing operations? YES ___ NO ___

(TB MED 530, para 4-28)

2. Are the sink compartments sized to handle the pots and pans used in the facility? YES ___ NO ___

(TB MED 530, para 4-28)

3. Are there stainless steel wire basket(s) provided for immersing utensils and other small items in the third (sanitizing) compartment when using hot water for manual sanitizing? YES ___ NO ___

(TB MED 530, para 4-28f(3))

4. If hot water sanitizing is used, is an integral heating device or fixture, which is capable of providing and maintaining 170 °F water in the third (sanitizing) compartment, installed in or under the sink? YES ___ NO ___

(TB MED 530, para 4-28)

5. Do dish tables and drain boards have a minimum pitch of 1/8 inch per foot to permit adequate draining of water? YES ___ NO ___

(NSF International Reference Guide, page 83)

6. Is a separate drain board space provided for clean and soiled utensils? YES ___ NO ___

(NSF International Reference Guide, page 83)

7. Is the drain board section for clean utensils raised at least 1/2 inch above the section for dirty utensils? YES ___ NO -

(NSF International Reference Guide, page 83)

8. Is the manual warewashing operation organized so that clean and dirty dishes DO NOT pass each other, thereby causing an opportunity for cross contamination?

YES ___ NO ___

(NSF International Reference Guide, page 83)

CHECKLIST 23 - WAREWASHING FACILITIES (General)

1. Are warewashing facilities separated with ceiling height partitions from the--

Food preparation area?

YES___ NO___

Main cooking area?

YES___ NO___

Service areas?

YES___ NO___

2. Do patron **flow** patterns allow patrons and staff to deliver soiled equipment and utensils without crossing through food preparation, storage, and serving areas?

Y E S___ N O___

(NSF International Reference Guide, page 8)

CHECKLIST 24 - HOT WATER GENERATING EQUIPMENT

1. Are the piping, fittings, and other items that directly contact the water **nontoxic**? YES ___ NO ___

Note: Primary concern is for leaching toxic metals, including lead, from the pipe and solder in the equipment. Installations and municipalities test drinking water for toxic metals. These results can be used to estimate the quality of the water entering a facility. The existing equipment manufacturer(s) may be able to certify that solders used were lead free. If not, the cold feed water and the hot water can be tested for lead.

(NSF International Reference Guide, chapter 5; and NSF International Manual on Sanitation Aspects of Installation of Food Service Equipment)

2. Do the piping, fittings, and other items that directly contact the water NOT affect the taste, odor, color, or turbidity of the water? YES ___ NO ___

(NSF International Reference Guide, chapter 5; and NSF International Manual on Sanitation Aspects of Installation of Food Service Equipment)

3. Is the hot water generating equipment sized to supply 140 °F water to **all sinks**, mechanical and manual warewashing operations, and other equipment? YES ___ NO ___

Note: The design should include adequate capacity to support peak operations such as cleanup after dinner and simultaneous preparation for supper.

(TB MED 530, para 5-6)

CHECKLIST 25 - WALK-IN REFRIGERATORS AND STORAGE FREEZERS

1. **Primary** considerations for **evaluating** the facility's walk-in refrigerators and freezers are--

Is there adequate storage space for the menu being or proposed to be served, the amount of refrigerated and frozen food being held, and inventory fluctuations such as delivery dates?

YES ___ NO -

Note: *Overcrowding of shelves, storage of food on the floor or duct boards, and inability to control leftovers are strong indicators of inadequate refrigeration.*

(TB MED 530, para 2-11a)

Are units capable of **rapidly** cooling pre-prepared potentially hazardous foods and leftovers?

YES ___ NO ___

(TB MED 530, paras 2-11 and 2-34)

Is there adequate lighting to identify and read product and date time labels?

YES ___ NO ___

(TB MED f30, para 6-18)

2. Are walk-in refrigeration units with built-in floors leveled and the floors **shimmed**, if necessary?

YES ___ NO ___

(NSF International Reference Guide, chapter 6, page 90)

3. Do shims extend under the whole section of **the walk-in (not JUST** the edges)? **(The** floor(s) should feel secure under foot. **There** should be no sagging **or cracks** between floor panels when they **are** walked on.)

YES ___ NO ___

(NSF International Reference Guide, pages 85-89)

4. Are shims spaced **no** more than 12 inches apart? (See Appendix G, figure G-1.) **YES**___ **NO**___

(NSF International Reference Guide, page 89)

5. Are floor sections and floor to wall junctions sealed? Check for accumulations of dirt and debris and possible insect harborage. (See Appendix G, figure G-3.) **YES**___ **NO**___

(NSF International Reference Guide, pages 85-96)

6. Are walk-in units that are set directly on a concrete masonry floor coved and sealed at all interior/exterior wall-floor junctions to ensure no gaps **1/16th** of an inch or greater exist? (See Appendix G, figure G-2.) **YES**___ **NO**___

(NSF International Reference Guide, pages 85-96)

7. Are the internal walls and floor easily cleanable, of durable construction, and in good repair? **YES**___ **NO**___

List locations and any deficiencies with refrigeration floors and walls: _____

8. Does the space between the top of the walk-in(s) and the ceiling meet **one** of the standards listed below? To indicate the standard met, **mark** the appropriate **"YES"** column.

The space, where open, is **NOT** less **than** 30 inches where clean-up personnel have to reach more **than** 8 feet **from** any side of the unit? **YES**___ **NO**___

(NSF International Reference Guide, page 92)

The space is **NOT** less than 24 inches where clean-up personnel have to reach less than 8 feet from any side of the unit.

YES ___ NO ___

(NSF International Reference Guide, page 92)

The space is effectively closed with vermin-tight paneling. (See Appendix G, figure G-4,

YES ___ NO ___

Note: Paneling **can be** either **fixed or removable** , **but the space must be ventilated and 16-gage screening used to cover any openings.**

(NSF International Reference Guide, page 92)

List locations and any deficiencies with enclosure for top of units: _____

9. **Is** shelving in good repair, easily cleanable?

YES ___ NO ___

10. Does shelving conform with NSF International Standard No. 7 and Underwriters Laboratories (UL) Standard 471?

YES ___ NO ___

(TB MED 530, para 4-1; NSF International Reference Guide, page 92)

11. Are remote condensate units installed any **from** the food preparation and serving area?

YES ___ NO -

(NSF International Reference Guide, pages 85-96)

12. **Are** stainless steel shelving units at least 6 inches above the floor surface or equipped with casters to **permit moving** for cleaning?

YES ___ NO ___

(Concept of Design and Operations for Army Dining Facilities, chapter 5)

13. In refrigerated storage units--

Is the temperature sensor unit located to measure the warmest part of the unit?

YES ___ NO ___

(Concept of Design and Operations for **Army** Dining Facilities, chapter 5)

Are the recorder units, if provided, wall-mounted and sealed?

YES ___ NO-

(Concept of Design and Operations for **Army** Dining Facilities, chapter 5)

List locations and any deficiencies: _____

CHECKLIST 26 - RECEIVING AREAS

1. Are receiving docks--

Four feet high? **YES** ___ **NO** ___

Covered at a height of **NOT** less than **14** feet 6 inches to facilitate docking by delivery trucks during inclement weather? **YES** ___ **NO** ___

Large enough to simultaneously accommodate 2-4 trucks (**2 1/2 tons** each) based on the capacity of the facility? **YES** ___ **NO** ___

(Concept of Design and Operations for **Army** Dining Facilities, chapter **4**)

2. Do all platform canopies extend 6 feet beyond the edge of the platform? **YES** ___ **NO** ___

Note: **Platform** canopies can be **either permanent construction or roll up type.**

(Concept of Design and Operations for **Army** Dining Facilities, chapter **4**)

3. Are cleaning facilities with floor drains, hot and cold running water, and a pressure spray cleaning source provided? **YES** ___ **NO** ___

(Concept of Design and Operations for **Army** Dining Facilities, chapter **4**)

Note: **The following items are included as they relate to control of insects and rodents.**

4. Are air curtains--

Provided on all exterior doors of the loading dock? **YES** ___ **NO** ___

(Concept of Design **and** Operations **for Army** Dining Facilities, chapter **4**)

As wide as the door opening to prevent the entrance of vermin?

YES ___ NO ___

(Concept of Design and Operations for Army Dining Facilities, chapter 4)

5. Do air curtains meet NSF International Standard 37?

YES ___ NO ___

(TB MED 530, para 5-33)

Note: Many times air curtains are turned off during work shifts, improperly installed, or not needed based on t&e fly population. If needed, consider less expensive and potentially more effective control measures, such as eliminating food and breeding sources or installing strip curtains or doors that swing both ways to facilitate deliveries, before installing air curtains on existing facilities.

6. Is night lighting installed so that it DOES NOT attract insects? .

YES ___ NO ___

7. Are all entrances to facility pest proof, including any air vents, floor drains, windows, and doors?

YES ___ NO ___

8. Do doors open outward?

YES ___ NO ___

9. Are doors tight fitting?

YES ___ NO ___

10. Is gap under door less than 1/4 inch to prevent rodent entry?

YES ___ NO ___

11. Are entrances for electrical, plumbing, air handling equipment, and other penetrations of walls, floors, and ceiling sealed?

YES ___ NO ___

(TB MED 530, para 5-33)

12. Are all operable windows, general and local air exhaust, and intake vents equipped with **screens** or tight-fitting louvers?

YES NO

Note: Sixteen (16) mesh window screen will be used for all windows and vents- If rodent entrance is a potential problem, the 1/4 inch hardware cloth will be used outside the window screen.

List locations and deficiencies: _____

CHECKLIST 27 - STORAGE (General)

- 1. **Are** separate storage areas provided for perishable and non-perishable food? YES___ NO___
- 2. **Is** a separate storage area provided for operation and cleaning supplies and equipment? YES___ NO-
- 3. Is a separate room provided for the storage of insulated food containers and insulated beverage containers? **YES**___ NO -
- 4. Are storage shelves of a **type** which D-NOT--
 Allow food debris to collect in crevices? **YES**___ NO -
 Provide insect **harborage**? **YES**___ NO___
- 5. **Is** adequate ventilation provided to the area where non-perishable ingredients are stored? **YES**___ NO -

Note: *Ventilation should be provided to keep relative humidity below 50%.*

(Concept of Design and Operations for **Army** Dining Facilities, chapter 5)

CHECKLIST 28 - ADMINISTRATIVE AREAS

1. Is the food **service** &ministration office located to provide an unobstructed view of food preparation areas?

YES ___ NO ___

(Concept of Design and Operations for **Army** Dining Facilities, chapter **8**)

2. Axe work surfaces within the office area provided at least 20 fc of light?

YES ___ **NO** ___

(Concept of Design and Operations for **Army** Dining Facilities, chapter **8**)

List locations and deficiencies: _____

APPENDIX A**REFERENCES**

A-1. Army Regulations

- AR 40-5 Preventive Medicine
- AR 420-10 Management of Installation Directorates Of Engineering and Housing
- AR 420-43 Electric Services

A-2. Technical Bulletin

- TB MED 530 Food Service Sanitation

A-3. Other Publications .

- ASHRAE** Std 62-1989 **Ventilation for Acceptable Indoor Air Quality. (Available from ASHRAE Publications Sales Department, 1791 Tullie Circle, N.E., Atlanta, GA 30329.)**
- EPA 570/9-89-007
(WH-550A) Cross-Connection Control Manual.
(Available from National Technical Information Service, 5285 Port Royal Rd., Springfield, VA 22161.)
- MIL STD-903 Sanitary Standards for **Commissary** Stores
- NFPA Std 96 Standard for the Installation of Equipment for the Removal of Smoke and Grease-Laden **Vapors from Commercial Cooking** Equipment, 1991 ed. **(Available from National Fire Prevention Association, Batterymarch Park, Quincy, MA 02269).**
- NSF International **Commercial Spray-Type** Dishwashing Machines. Standard 3
(Available from NSF International, P.O. Box 130140, Ann Arbor, MI 48113-0140, or by **commercial** telephone 313-769-8010.)

- NSF International Standard 7 Food **Service** Refrigerators and Storage Freezers . (Available from NSF International, P.O. Box 130140, Ann Arbor, MI 48113-0140, or by commercial telephone 313-769-8010.)
- NSF International Standard 37 Air Curtains for Entranceways in Food Establishment. (Available from NSF International, P.O. Box 130140, Ann Arbor, MI 48113-0140, or by commercial telephone 313-769-8010.)
- NSF International Standard 52 Supplemental Flooring. (Available from NSF International, P.O. Box 130140, Ann Arbor, MI 48113-0140, or by commercial telephone 313-769-8010.)
- 29 CFR 1910 1993 rev Occupational Safety and Health Standards. (**Available** for reference at the local installation Staff Judge **Advocate** Office.)
- UL Standard 471 Refrigerator and Freezer Equipment. (Available from Underwriters Laboratories, Inc., 333 Pfingsten Road, Northbrook, IL 60062-2096.)

A-4. **Unnumbered Publications**

Concept of Design and Operations for Army Dining Facilities.
(Available from U.S. **Army** Troop Support Agency, Ft Lee, VA 23801.)

Design of Grease Filter Equipment Kitchen Exhaust Systems.
(Available from Research Products Corporation, 1015 East Washington Ave., P.O. Box 1467, Madison, WI 53701.)

Handbook of Fundamentals, latest edition. (Available from **ASHRAE**, 1791 Tullie Circle, N.E., Atlanta, GA 30329.)

Industrial Ventilation, **A Manual of Recommended Practice**, latest edition. (Available from American Conference of Governmental Industrial Hygienists, 6500 Glenway Avenue, Cincinnati, OH 45211-4438.)

Manual on Sanitation **Aspects of Installation of Food Service Equipment**, current edition. (Available from NSF International, P-O. Box 130140, Ann Arbor, MI 48113-0140, or by commercial telephone 313-769-8010.)

NSF International Reference Guide, Sanitation Aspects **of Food Service Facility Plan Preparation and Review**, latest edition. (Available from NSF International, P.O. Box 130140, Ann Arbor, MI 48113-0140, or by commercial telephone 313-769-8010-J

U.S. Department of Agriculture, **List of Proprietary Substances and Food Compounds Authorized for Use Under USDA Inspections and Grading programs**. (Available from USDA, Food Safety and Inspection Service, Washington, DC 20250.)

APPENDIX B
SERVICE CONNECTIONS

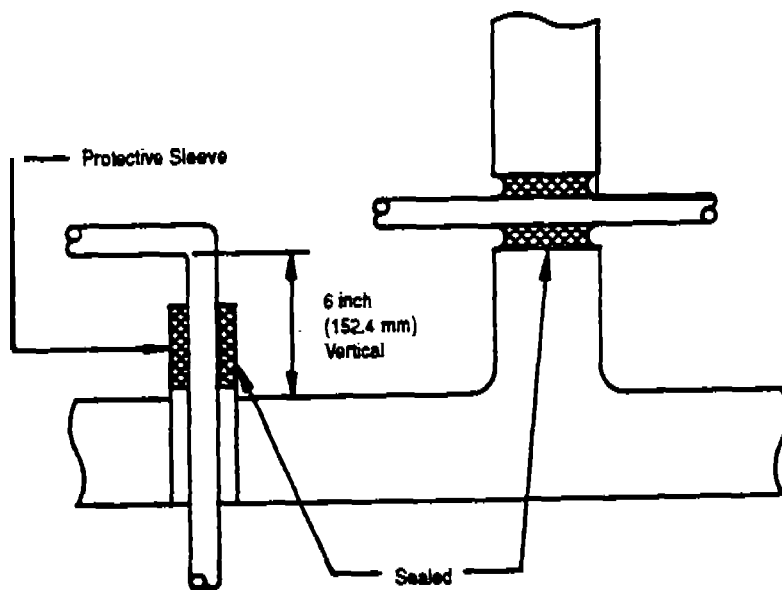

Utility and Service Line Installation

APPENDIX C**POTENTIAL CROSS-CONNECTION LOCATIONS**

1. Water closet bowls equipped with flushometer **valves** or flushing tanks with submerged float operated ballcocks.
2. Boiling equipment with water inlets subject to pollution by either gravity or siphonic action.
3. Water- jet cellar **drainers**.
4. Washbasins with inlets **below** the rim of the fixture.
5. Drinking fountains with the drinking orifice below the rim of the fixture. Take special care that the pressure relief or any other orifice in the supply is not below the rim of the fixture.
6. Warewashing machines.
7. Laundry trays with **faucets** below the **rim**.
8. Sinks with faucets or water inlets below the rim, and sinks with loose hose connections **not provided** with a proper retractor **or backflow prevention device**.
9. Prewash dishwashing sinks or machines with **water** inlets below the rim.
10. Water **supply to water-jacketed**, grease-intercepting traps with case partitions.
11. Steam **tables**.
12. Water supplied **food** service equipment with water inlets below the fill line. **Examples include coffee urns, juice vats, automatic** potato skinners, etc.
13. Post-mix carbonated beverage machines which can potentially backflow carbon dioxide and carbonated water into the water **supply**.

14. Bin-type ice machine with drains directly connected to the floor drain.

15. **All** hose bibbs.

APPENDIX D

BACKFLOW PREVENTION DEVICES

Source: Catalog No. C-BPD-20, Watts Regulator Company,
North Andover, MA 01845

BACKFLOW PREVENTER FOR VENDING MACHINE WATER SUPPLY LINES

Size:
3/8" F.C.T.

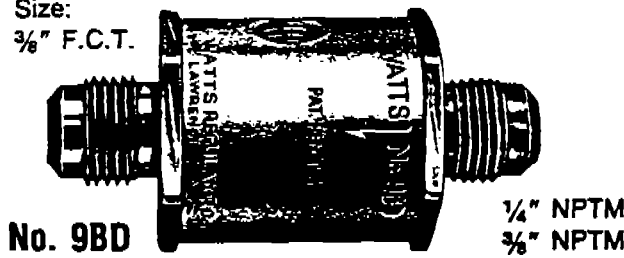

HOW IT OPERATES

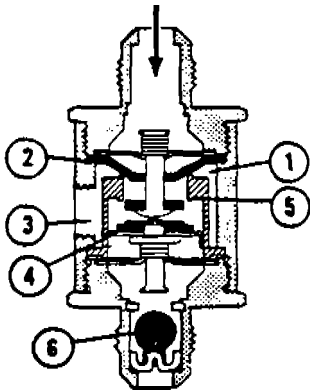

Valve Opened Flowing Under Pressure

With flow through valve, primary disc (1) opens away from diaphragm seal (2). Atmospheric port (3) remains closed by deflection of diaphragm seal. Secondary disc (4) opens away from downstream seat (5). Ball check (6) opens away from ball check seat permitting flow of water through valve.

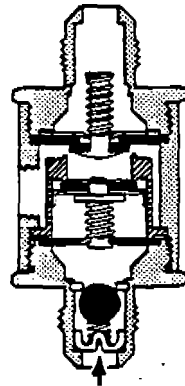

Valve Closed by Backpressure in System

With a backpressure condition, ball check seats against ball check seat. Secondary disc seals against downstream seat. Primary disc seals against diaphragm. Atmospheric port is now open permitting air to enter air break chamber. In the event of fouling of downstream check valve, leakage of CO₂ gas would be vented to atmosphere through the vent port safeguarding the potable water system from CO₂ gas contamination.

This valve should only be used in areas where spillage of water could not cause damage. Install a vent discharge line to the vent outlet of No. 9BD and vent to a safe place of disposal with adequate ventilation where CO₂ discharge is not a hazard.

NOTE: Owner/installer or code official must insure that CO₂ gas containers only be used in open properly ventilated area.

DIMENSIONS (are approximate)

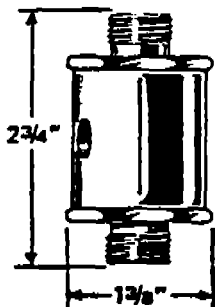

CAPACITY

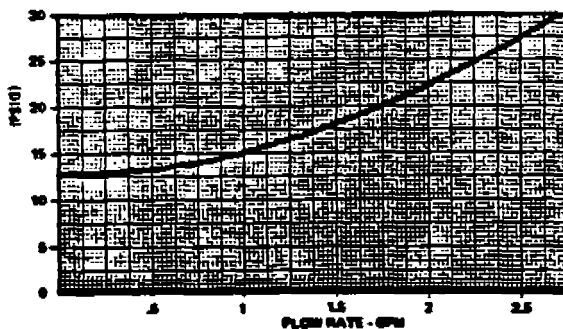

FOR LIQUID VENDING MACHINES

No. 9BD is for protection against backflow of carbon dioxide gas and carbonated water into the water supply system to vending machines, thus eliminating the hazardous reaction of carbon dioxide with copper tubing.

Features unique, double check valve assembly for positive, dependable seating and also equipped with a ball check valve which is a third-check member, its main function being to prevent backpressures caused by pump cycle. Instant check valve response prevents unnecessary vent discharge during pump "off-cycle".

Vent discharges CO₂ gas to atmosphere in the event of fouling or malfunction of check No. 2 thereby safeguarding the potable water system from CO₂ gas contamination. Flow way design features minimize pressure drop across valve for maximum pump performance. Also recommended for other liquid vending machines such as coffee, tea etc. Vertical or horizontal installation.

SPECIFICATIONS

Max* pressure 150 lbs. Max. temperature 140°F. Suitable for initial pressures up to 150 lbs. All stainless steel body and heavy duty rubber parts assure the longest and most dependable operating life. All -rubber compounds comply with FDA food additive regulations.

STANDARDS

Designed to meet or exceed A.S.S.E. Std. 1032. Meets the requirements of New York City Health Code Section 81.47 and NSF Std. No. 25, Revised Items 4.352 and 4.35.3. Also approved by Independent testing completing over 2,000,000 successful pump cycles with positive backflow -protection and trouble free performance.

No. 9BD Backflow Preventer



No. 9BD Backflow Preventer

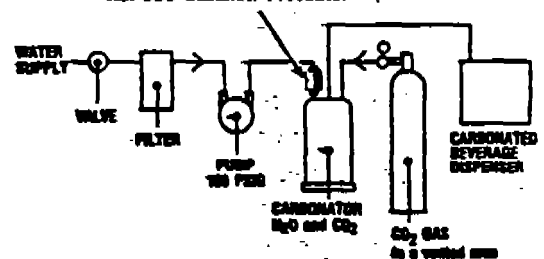

HOSE CONNECTION

FOR BACKFLOW PREVENTION AS REQUIRED BY PLUMBING CODE CROSS CONNECTION CONTROL — Hose Supply Outlets that are not subject to continuous pressure

Series 8 are unique devices specially made for hose thread faucets with portable hoses attached. Their purpose is to prevent the flow of contaminated water back into the safe drinking water supply . . . and installation requires no plumbing changes, device screws directly to the sill cock.

No. 8A is furnished with an exclusive "non-removable" feature that prevents removal from sill cock. This "Vandal Proof" feature is preferred by most Plumbing Codes. (Pat. Nos. 3,459,443 and 3,171,423)

APPLICATIONS

Series 8 can be used on a wide variety of installations such as service sinks, swimming pools, developing tanks, laundry tubs, wash racks, dairy barns, marinas and general outside gardening uses.

Series 8 is tested and certified under ANSI A112.1.3 (ASSE 1011), which precludes use under continuous pressure.

IMPORTANT: This valve should only be used in areas where spillage of water could not cause damage.

OPTIONS

No. S8C, 8C, 8AC, 8BC or NF8-C are furnished with chrome finish body.



STANDARDS

Tested and approved in conformance with A.S.S.E. Std. 1011 and C.S.A. 864.2.

No. S8, 8A, 8B, NF8, and 8P are listed by IAPMO.

CAPACITY

PERFORMANCE CURVE

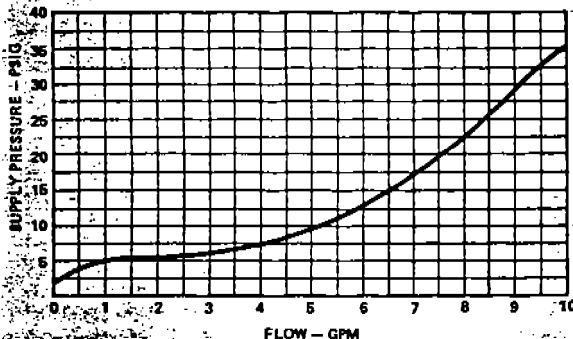

No. S8C 1/2" or 3/8"

Specially made for use with tub and shower hand spray sets. Installs without plumbing changes between shower-head and hose.

No. S8 plain brass.

Send for ES-S8.



No. 8A
No. BP
3/4" HT

No. 8A for portable hoses attaches to hose thread faucets, requires no plumbing changes as it is screwed directly to the sill cock.

No. 8P same as 8A except body made of reinforced thermoplastic.

Send for ES-8 and ES-BP.

OPERATION OF

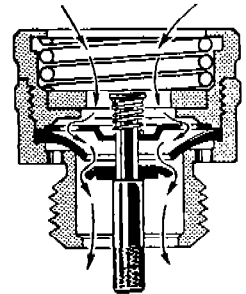
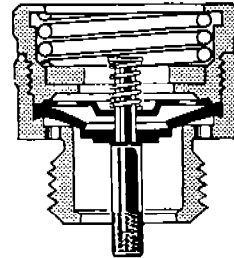
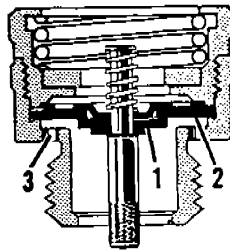

No. 8A in closed position Before flow begins, atmospheric ports are sealed off before lower disc opens to permit flow. Atmospheric ports are open (3) during no flow.

Lower disc opens away from atmospheric disc (1) seals against diaphragm seal allowing flow through the valve with slight pressure drop.

CONSTRUCTION

No. 8A - Furnished with exclusive "Non-removable" feature and standardly equipped to allow sill cock to be drained. Note: Device is Non-removable once installed.

No. 8 - Similar to the No. 8A except it is furnished without the "Non-removable or draining feature."

No. 8B - Similar to the No. 8 except it has a breakaway set screw to provide a tamper-proof feature.

No. NF8 - Especially made for wall and yard hydrants. Permits manual draining for freezing conditions.

No. 8P - Furnished with exclusive patented "Non-removable" feature and standardly equipped to allow sill cock to be drained. Constructed of durable, corrosion-resistant, reinforced thermoplastic. Tamper-proof feature. Patent No. 4821763.

DRAINAGE FEATURES TO PREVENT FREEZING

Watts No. 8A, 8B and 8 are standardly equipped to allow sill cocks to be drained. To do this, remove hose coupling and lightly pull knurled tip of stem at outlet of valve to allow drainage of collected water.

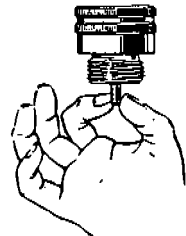

Note: Do not use No. 8, 8A, 8B, 8P Hose Bibb Vacuum Breakers on frost-free hydrants. Specify No. NF8.

VACUUM BREAKERS



No. 8 3/4" HT

Similar to No. 8A Series except it is furnished without the "Non-removable" or draining feature. Send for ES-8.



No. NF8 3/4" HT

No. NF8 for wall and yard hydrant. Permits manual draining for freezing conditions.

WATTS No. 8A Series

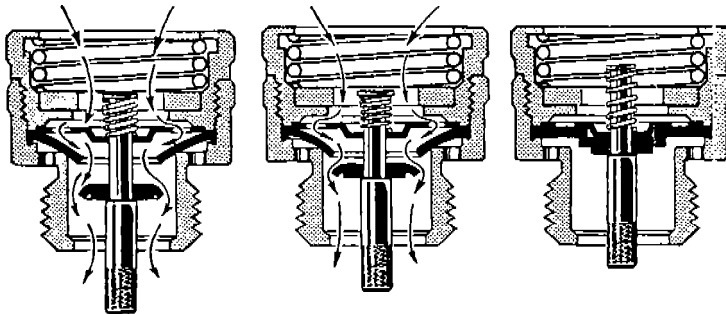

Fully opened valve, illustrating poppet action to provide high capacity with minimum pressure drop through valve.

With reduction in water supply pressure, disc returns closer to diaphragm. Diaphragm seals off atmospheric ports preventing unnecessary leakage.

With loss of water supply, disc seals tightly against diaphragm preventing back-siphonage or backflow of water and opens atmospheric ports.

INSTALLATION

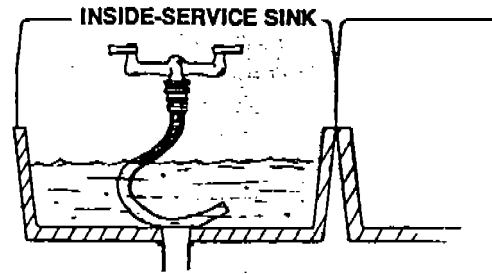

WHAT IS BACK-SIPHONAGE?

A reversal of normal flow in the system caused by a negative pressure (vacuum or partial vacuum) in the supply piping.



DIMENSIONS-WEIGHT

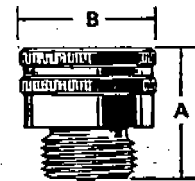

No.	Size	A	B	Weight
8, 8C, 8B, 8BC	3/4" HT	1 1/2"	1 3/8"	3/4 lb.
8A, 8AC	3/4" HT	1 1/2"	1 1/2"	3/4 lb.
NF8, NF8C	3/4" HT	2"	1 1/2"	1/2 lb.
8P	3/4" HT	1 1/16"	1 3/8"	1 1/2 oz.

Frost-Proof Automatic Braining Wall Hydrants with Hose Connection Vacuum Breaker Backflow Preventer

Series FHV

Meets A.S.S.E. Std. 1019
Listed by IAPMO (UPC)
Certified to CSA Std B125 and 864.2

- Self drains automatically
- Positive seat washer cut off
- Designed and manufactured to prevent contamination of the safe drinking water supply from either back-siphonage or backflow pressure
- No burst feature
- Cycle tested to provide years of service

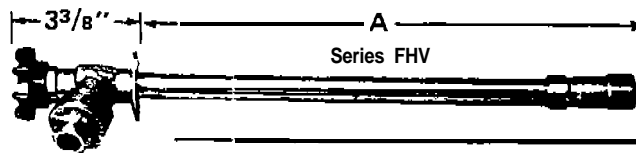

NO.	EDP Code	Inlet No.	Inner Pack Size	Qty.	Master Carton Qty.	Wgt. (lbs.)	Dimensions
							(Inches)
Inlet 1/2" copper x 1/2" male I.P.S.							
FHV-1	723090	4"	4"	1	15	20	8.40
FHV-1	723092	6"	6"	1	15	20 1/4	10.41
FHV-1	723094	8"	8"	1	15	23 1/2	11.41
FHV-1	734096	12"	12"	1	15	25 1/2	14.42
FHV-1	723098	14"	14"	1	15	27	16.43
FHV-1	723100	14"	14"	1	15	29	18.44
Inlet 3/4" male I.P.S. x 1/2" female I.P.S.							
FHV-2	723102	4"	4"	1	15	20	8.40
FHV-2	723104	6"	6"	1	15	20 1/4	10.41
FHV-2	723106	6"	6"	1	15	23 1/2	12.41
FHV-2	723108	10"	10"	1	15	25 1/2	14.42
FHV-2	723110	12"	12"	1	15	27	16.43
FHV-2	723112	14"	14"	1	15	29	16.44

APPENDIXE
HOT WATER GENERATING EQUIPMENT

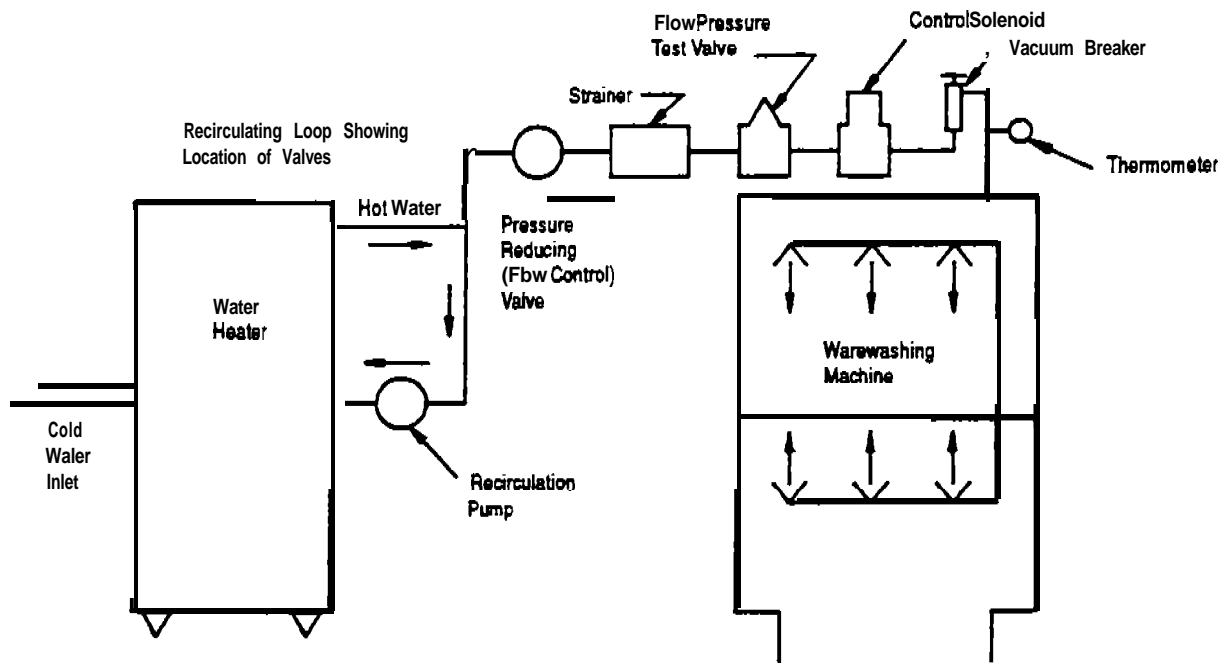

Location of **Pressure** Reducing or Flow Control Valve in a 180 °F (82.2 °C) Final Rinse Water Recirculation Loop

APPENDIX F
EQUIPMENT INSTALLATION

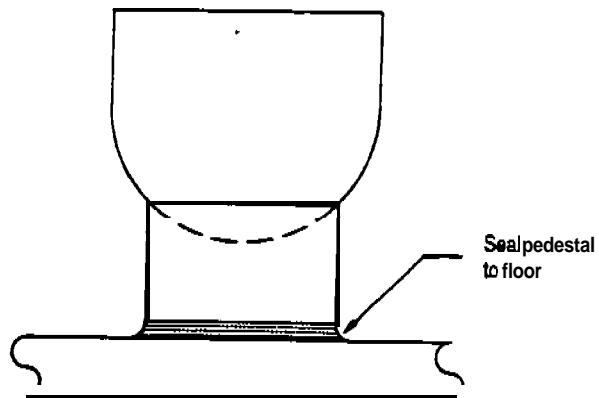

Figure F-1. Pedestal Mounted Kettle

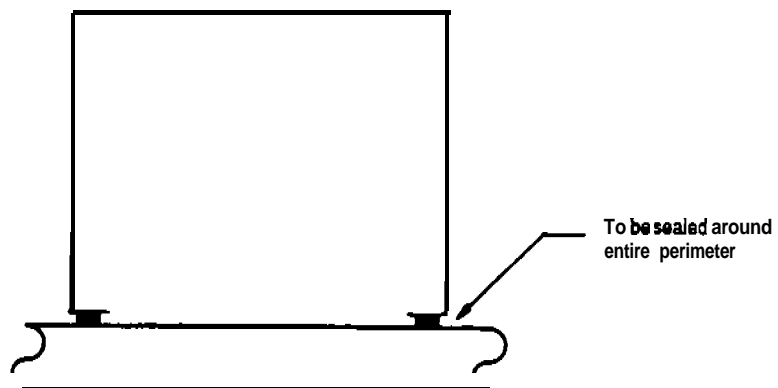

Figure F-2. Floor Mounted Equipment Installation - Side View

Where equipment has closed bottom without air spaces and/or of ferrous material sits on masonry base, top and sides (ends) of base to be waterproofed with sealant to prevent condensation and capillary action from rusting bottom of unit

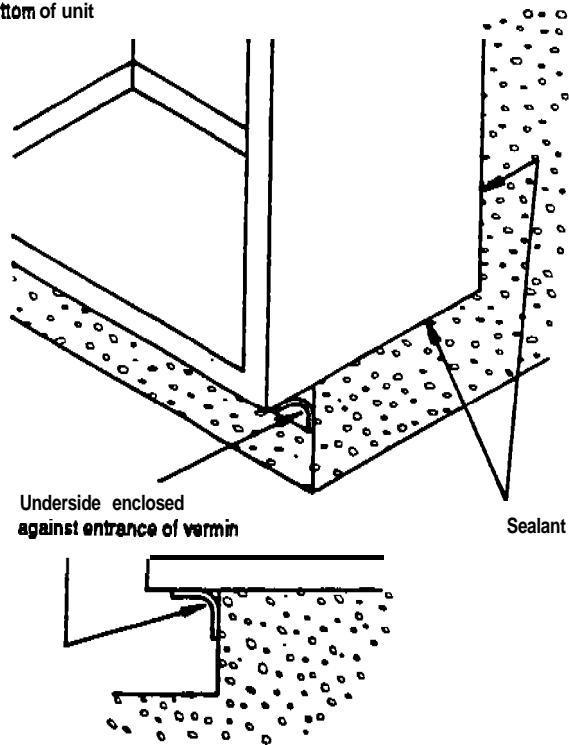

Figure F-3. Solid **Masonry** Base Installation - Side View

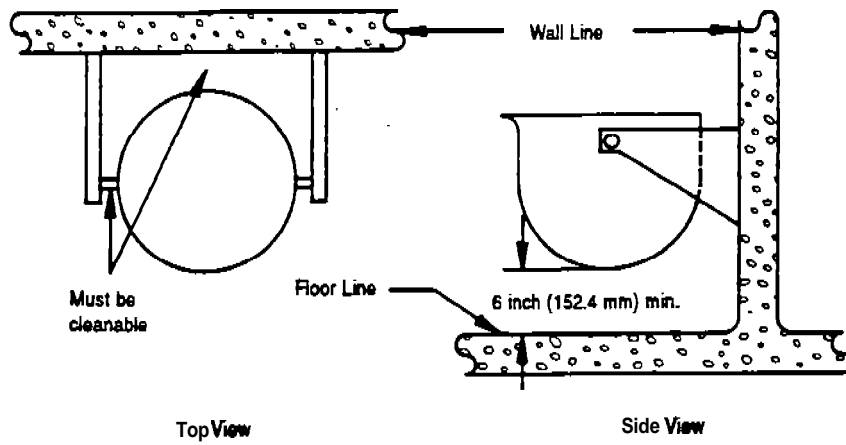

Figure F-4. Installation of Cantilevered Equipment

APPENDIX G
WALK-IN REFRIGERATORS AND FREEZERS

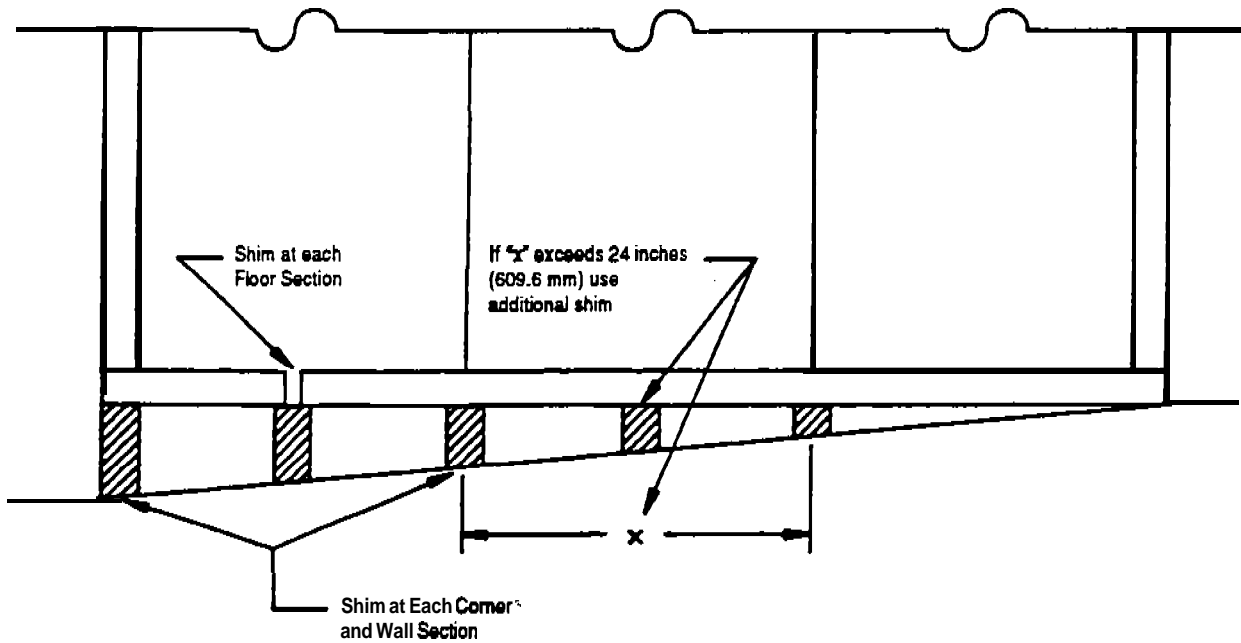

Figure G-1. Leveling Bottoms with Shims

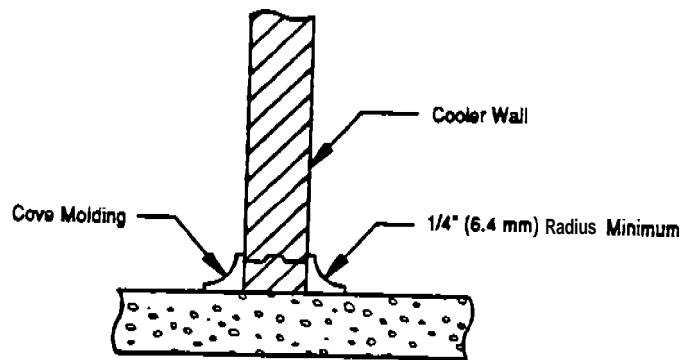

Figure G-2. **Installation** of Floorless Walk-in on **Existing** Floor

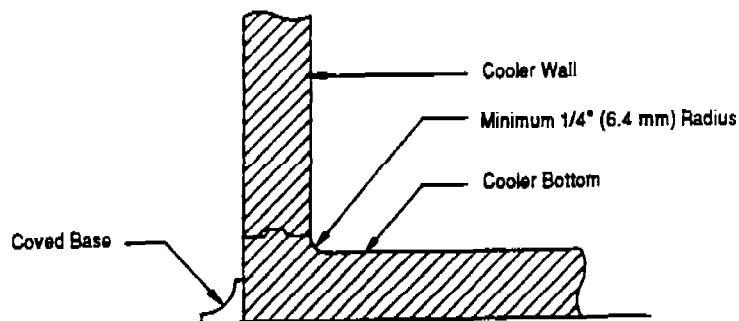

Figure G-3. Installation of Prefabricated walk-in with Floor

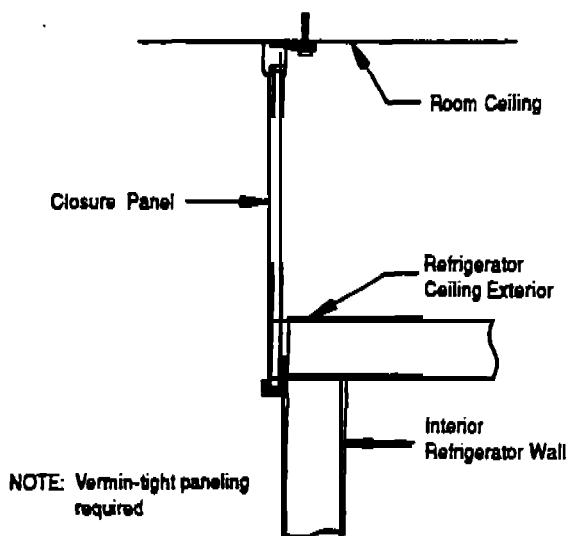

Figure G-4. Enclosure of Space Between Top of Walk-in and the Ceiling

GLOSSARY

Section I. Abbreviations

AAFES

Army and Air **Force** Exchange Service

ACGIH

American Conference of Governmental Industrial Hygienists

ASHRAE

American Society of Heating, Refrigeration, and Air Conditioning Engineers

BOCA

Building Officials' & Code Administrators' Plumbing Codes

cfm

cubic feet per minute

CPR

Code of Federal Regulation

CIP

clean-in-place

CO₂

carbon dioxide

CV

capture velocity

EM

enlisted man (men) or enlisted woman (women)

EPA

U.S. Environmental Protection **Agency**

fc

foot **candle(s)**

fpm

feet per minute

GF'CI
ground-fault circuit interrupter

IMA
installation medical authority

LEV
local exhaust ventilation

MIL-STD
military standard

NCO
noncommissioned officer

NFPA
National Fire Protection Association

NSF International
(formerly National Sanitation Foundation)

OSHA
Occupational Safety and Health Administration

psi
pounds per square inch

UL
Underwriters Laboratories

USAEHA
U.S. Army Environmental Hygiene Agency

USDA
U.S. Department of Agriculture

Section II. **Terms**

Accessible

Capable of being exposed for the purpose of cleaning and inspection using simple tools such as a screwdriver, **pliers**, or open-end wrench.

Backflow

A reverse of water flow from nonpotable into the potable water supply.

Capture velocity

The velocity of the exhaust air, at the point of generation, necessary to overcome opposing air currents and to capture the contaminated air at that point and **cause** it to flow into the hood.

Cleaning

The physical removal of food residues, ingredients, and other soiling materials.

Duct velocity

The velocity of the air **as** it travels through the duct **work**.

Easily cleanable

Readily accessible; of such materials, finishes, and so fabricated that soil and debris can be effectively removed by normal cleaning methods.

Equipment

All stoves, ovens, ranges, hoods, slicers, mixers, meat blocks, tables, counters, refrigerators, freezers, sinks, dish washing machines, **steam** tables, and-similar items, other than utensils, used in the operation of a food **service facility**.

Exhaust air volume

Total volume (Q) of air exhausted by a **LEV** system. Determine Q by averaging the face velocities of the **LEV** and multiplying the average face velocity (V) by the effective open face area (A) of the **LEV**.

Face velocity

The velocity of the exhaust air measured at the open face of the hood or opening to the **LEV**.

Fire protection

Grease fires within hoods **and** duct work are a major hazard within food **service** facilities. The National Fire Protection Association (NFPA) Standard 96, **Standard for the Installation of Equipment for the Removal of Smoke and Grease-Laden Vapors from Commercial Cooking Equipment**, covers the basic requirements for the design, installation, and operation of commercial cooking equipment exhaust systems. The installation fire marshal is normally the authority having jurisdiction for evaluating the fire protection aspects of the installation, and operation of kitchen **LEV** systems.

Food service facility

Any fixed or mobile field or garrison restaurant; snack bar; food plant; dining facility; medical treatment dining facility; canteen; bar; officers', NCO, or EM club; contractor-operated cafeteria; soda fountain; sandwich shop; delicatessen; exchange; commissary; troop issue subsistence activity; meat market; catering kitchen, or any other type of facility or **operation** other than a private residence in which food or drink is prepared, processed, stored, issued, vended, or served on the premises or elsewhere, with or without **charge**.

Garbage

Garbage are those wastes capable of decomposing resulting from the handling, preparation, cooking, and serving of food.

Installation Medical Authority (IMA)

IMA refers to the unit surgeon, **command** chief surgeon, U.S. Army Medical Department Activity or U.S. Army Medical Center commanders, and the director of the health services or his or her representative responsible for provision of medical support at the unit, command, or installation concerned in consultation with veterinarians, sanitary engineers, environmental science officers, and entomologists.

Lavatory

A basin or **similar** vessel used exclusively for washing the hands, **arms**, and face to include associated plumbing and potable running water supply.

Portable

Equipment that is small **and** light enough to be moved easily by one person and **has--**

- a. No utility connection, or
- b. A utility connection that disconnects quickly, or
- c. Flexible utility connection line of sufficient length to **permit** the equipment to be moved for easy *cleaning*.

Readily (or easily) removable

Capable of being **detached from** the main unit without the use of tools.

Refuse

All non-decomposing solid waste.

Removable

Capable of being detached from the main unit with the use of simple tools, such as screwdrivers, **pliers**, or open-end wrenches.

Utensil

Any implement, such as tableware and kitchenware, used in the storage, preparation, display, transportation, serving, or consumption of food.

Ventilation

The removal or supply of air from a general area, room, or building to eliminate irritants and objectionable odors.

a. Natural ventilation is achieved by opening windows or **doors** to create an air draft (usually inadequate for kitchen and dining facility areas).

b. Mechanical ventilation is provided by heating, ventilating, and air conditioning equipment. This general or dilution ventilation is usually used to control non-particulate fumes and odors and for heat control.

c. **Local** exhaust ventilation is used to control airborne **particulate** contamination at its source and is achieved with an exhaust hood and duct **system**.

Vermin

Small vertebrates or arthropods that are objectionable to man or pose a risk to health (rodents, cockroaches, flies, etc.)

Wet locations

Wet locations are defined in the National Electric Code. Any locations: where there could be standing water; where water hoses are used for cleaning; and locations within 6 feet of a sink are considered wet locations.

